

NEW Amprobe Multitester

Single Megohmmeter, Single Ground Resistance Tester, Combination Megohmmeter/Ground Resistance Tester or Combination Megohmmeter/Ground Resistance Tester/Power Quality Tester

- Test Leads, Auxiliary Electrodes, PC Software and CT are Included for a Complete Instrument
- Auto Ranging
- 2MB of Internal Memory to Store Measurements
- RS-232 Download to a Personal Compute
- Safety: CATIII 600V Phase to Phase, CAT III 300V Phase to Ground

B

Megohmmeter (AMB-6D)

- Tests insulation of wires, cables, transformers and electrical motors
- Comes as a complete kit including test leads and PC software
- Selectable test voltages up to 1000V
- Programmable timer to perform the Dielectric
- Sensitive Ohmmeter for checking resistance of motor windings
- Selectable polarization of ohmmeter for checking grounding continuity
- Automatic voltmeter warns against hazardous energized systems
- Fast and easy to use, rugged durable design Internal memory to store measurements for future reference
- Data download to PC
- Safety CAT III 250V

Ground Resistance Tester (GP-2)

Ground Resistance and Resistivity functions:

- Measures Earth ground resistance - 3 point (fall of potential) or 2 point tests
- Automatically calculates resistivity - 4 point test
- Automatic voltage measurement prevents false measurements
- Automatically applies three testing frequencies for the most accurate readings

Megohmmeter/Ground Resistance Tester (MT-1000)

Megohmmeter functions:

- Tests insulation of wires, cables, transformers and electrical motors
- Selectable test voltages up to 1000V
- Programmable timer to perform the Dielectric Absorption Ratio Test
- Sensitive Ohmmeter for checking resistance of motor windings
- Selectable polarization of ohmmeter for checking grounding continuity
- Automatic voltmeter protects against misuse on hazardous energized systems

Ground Resistance and Resistivity functions:

- Measures Earth ground resistance - 3 point (fall of potential) or 2 point tests
- Automatically calculates resistivity - 4 point test
- Automatic voltage measurement prevents false measurements
- Automatically applies three testing frequencies for the most accurate readings

Power Quality/Megohmmeter/Ground Resistance Tester (MT-2000)

Single phase Power Quality functions:

- Detects and records voltage transients, sag and surges with sampling rate of 130 μ s
- Built in scope displays waveforms
- Records up to 64 parameters simultaneously
- Manual and programmable recording start
- Password protection
- Selectable fundamental frequency of 50 or 60 Hz
- Special data compression system and user selectable rates allow recording from several hours to several years
- Outlet or battery powered

Megohmmeter functions:

- Tests insulation of wires, cables, transformers and electrical motors
- Selectable test voltages up to 1000V
- Programmable timer to perform the Dielectric Absorption Ratio Test
- Sensitive Ohmmeter for checking resistance of motor windings
- Selectable polarization of ohmmeter for checking grounding continuity
- Automatic voltmeter protects against misuse on hazardous energized systems
- Ground Resistance and Resistivity functions:
 - Measures Earth ground resistance - 3 point (fall of potential) or 2 point tests
 - Automatically calculates resistivity - 4 point test
 - Automatic voltage measurement prevents false measurements
 - Automatically applies three testing frequencies for the most accurate readings



Electrical Test Instruments

NEW Amprobe Multitester — continued

AMB-6D Includes: Carrying case (GP-2CC), Special download cable (C200)1), Test leads set (complete set of 3) (MT1-LEADS), PC Software Toplink (www.amprobe.com, and Instruction Manual (www.amprobe.com)

GP-2, MT-100 and MT-2000 Includes: Instrument carrying case (CC-MT1), Carrying case containing: 4 earth rods and 4 test leads, banana – alligator clip (GP-2CON), Special download cable (C2001), Test leads set -4 test leads, 4 alligator clips, 2 test probes (MTL-MT1), PC Software Toplink (www.amprobe.com) and Instruction Manual (www.amprobe.com)

MT-2000 also Includes: Clamp 1000A/1V (DM-CT-HTA), External power supply 12VDC (DM-EXTPS)

Specifications and Ordering Information

Mfg #	GP-2	MT-1000	MT-2000	AMB-6D
Power Quality				
AC Voltage	NA	NA	0 - 600V (+/- 3% Rdg + 2 LSD)	NA
AC Current	NA	NA	5 - 3000A* (+/- 0.5% Rdg + 2 LSD)	NA
Power	NA	NA	W, VAR and VA (+/- 1% Rdg + 2 LSD)	NA
Energy	NA	NA	kWh, VAR) and VAh (+/- 1% Rdg + 2 LSD)	NA
Peak Demand	NA	NA	kW (+/- 1% Rdg + 2 LSD)	NA
Frequency measurement	NA	NA	47.0 to 63.6 Hz (+/- 1% Rdg + 1 LSD)	NA
True and Displacement Power Factor	NA	NA	0.00 – 1.00	NA
Harmonics	NA	NA	Up to 49th	NA
Phase sequence	NA	NA	1/2/03	NA
Co-generation	NA	NA	Computes incoming and outgoing energy	NA
Selectable Fundamental Frequencies	NA	NA	50/60 Hz	NA
Available Recording Time	NA	NA	Several hours to several years depending on setup	NA
Megohmmeter				
50 VDC	NA		0.01-19.99, 49.9 (+/- 2% Rdg + 2 LSD) 49.9 - 99.9M Ω (+/- 5% Rdg + 2 LSD)	
100 VDC	NA		0.01-19.99, 99.9 +/- (2% Rdg + 2 LSD) 99.9 - 199.9M Ω (+/- 5% Rdg + 2 LSD)	
250 VDC	NA		0.01-19.99, 199.9, 249 (+/- 2% Rdg + 2 LSD) 249 - 499 M Ω (+/- 5% Rdg + 2 LSD)	
500 VDC	NA		0.01-19.99, 199.9, 499 (+/- 2% Rdg + 2 LSD) 499 - 999 M Ω (+/- 5% Rdg + 2 LSD)	
1000 VDC	NA		0.01-19.99, 199.9, 999 (+/- 2% Rdg + 2 LSD) 999 - 1999 M Ω (+/- 5% Rdg + 2 LSD)	
Low Resistance (without timer)	NA		0.01-19.99, 99.9 Ω (+/- 2% Rdg + 2 LSD)	
Low Resistance (with timer)	NA		0.01-9.99 Ω (+/- 2% Rdg + 2 LSD)	
Ground Resistance				
Ground resistance			0-19.99, 199.9, 1999 Ω +/- (5% Rdg + 3 LSD)	NA
Ground resistivity			0.6- 125.6 Ω m, 0.125-1.256, 19.99, 199.9 k Ω m (+/- 5% Rdg + 3 LSD)	NA
Order #	GP-2	MT-1000	MT-2000	AMB-6D
Price				

Accessories

Order #	Mfg #	Description	Price
MPRS-USB	RS-USB	USB to RS-232 Adapter	
MPACF-3000SR	SR3000SR	AC Flexible Clamp-on Attachment	
MPTH-ACC	TH-ACC	Temperature and Humidity Probe	
MPLM-ACC	LM-ACC	Multi range luminance probe	
MPSM-ACC	SM-ACC	Sound level meter	
MPCT-LEA	CT-LEA	Leakage current probe	
MPCC-DM-III	CC-DM-III	Hard Case	

B

Electrical Test Instruments

AEMC Ground Resistance Tester

- New Improved Noise Immunity
- No Ground Rods or Wires Needed
- New 0.1Ω to 1200Ω Ground Resistance Range
- 1 mA to 30A Ground or Leakage Current
- 9.25 x 3.94 x 2.17"; 2.2 lbs.
- Jaw Opening 1.25"

These testers are suitable for ground resistance measurements on multipoint ground systems. Clamp the jaws around the conductor at any point, and read directly. You can measure either ground resistance or a leakage current.

The 5718E is a "deluxe" model which includes an alarm mode which signals audibly and visually if your reading is above or below the set point. Built-in non-volatile memory allows storage and recall of up to 99 current or resistance measurements. This unit includes a one-year warranty and has UL, CSA, and GS approvals. Noise Immunity has been greatly improved through use of higher frequency for the test voltage.

Each Unit Includes: 25Ω calibration loop, hard carrying case, 9V alkaline battery, and user's manual.

2117.61 
In Use

Approvals: IEC 1010-1, CAT III 300V

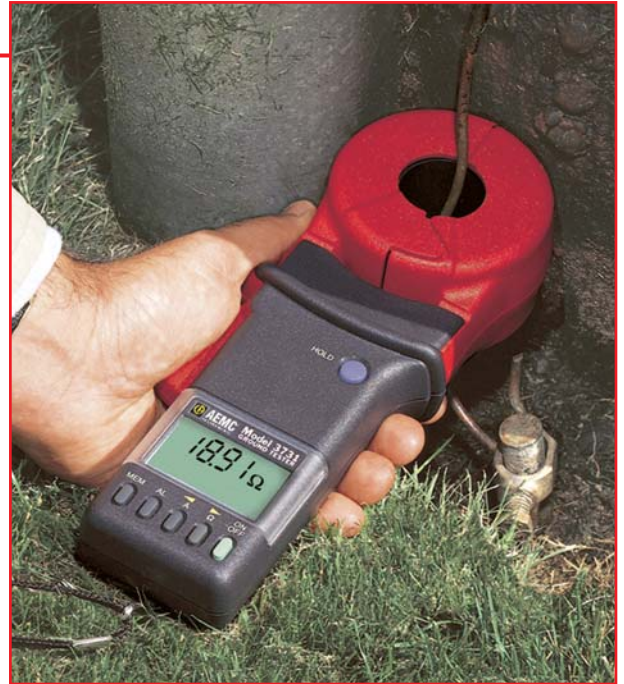

Specifications

Ground Resistance Measurement Range	Range	Resolution	Accuracy
Autoranging 0.01 to 1200Ω:	0.1Ω to 1.00Ω	0.01Ω	±(2.0% + 0.02Ω)
	1.0 to 50Ω	0.1Ω	±(1.5% + 0.1Ω)
	50 to 100Ω	0.5Ω	±(2.0% + 0.5Ω)
	100 to 200Ω	1Ω	±(3.0% + 1Ω)
	200 to 400Ω	5Ω	±(6.0% + 5Ω)
	400 to 600Ω	10Ω	±(10.0% + 10Ω)
	600 to 1200Ω	50Ω	Approx: ±(25% ±50Ω)
Ground or Leakage Current Measurement Range	Range	Resolution	Accuracy
Autoranging 1 mA to 30.00A RMS:	1 to 300 mA	1 mA	±(2.5% + 2 mA)
	0.300 to 3A	0.001A	±(2.5% + 2 mA)
	3.00 to 30.00A	0.01A	±(2.5% + 20 mA)
Jaw Opening:	1.38" (35 mm) fits rods and conductors up to 1000 MCM		
Display:	3 ¹ / ₄ -digit LCD		
Power:	9V alkaline battery		
Operating Temperature:	-10 to 55°C (14 to 131°F)		
Size:	9.25 x 3.94 x 2.17" (235 x 100 x 55 mm)		
Weight:	2.2 lbs (1 kg)		

Ordering Information

Order #	Mfg #	Description	Price
MP5717E	2117.60	Model 3711 Clamp-On Ground Resistance Tester	
MP5718E	2117.61	Model 3731 Clamp-On Ground Resistance Tester with Alarm and Memory	

Transcat Accredited Calibration with Data	CALL
Transcat Accredited Calibration without Data	CALL



2117.61 



Revolution in Ground Testing

Adapted from Understanding Ground Resistance Testing

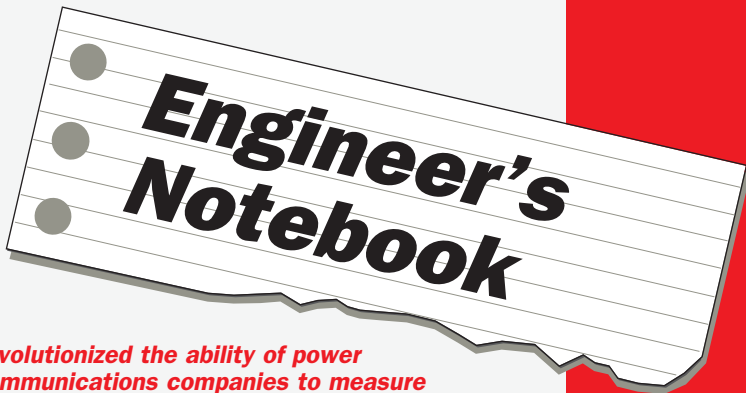

The clamp-on ground tester has revolutionized the ability of power companies, manufacturers, and communications companies to measure ground resistance values. This measurement method is a departure from the conventional fall of potential (FOP) test. But in an appropriate environment, there are several benefits.

- 1. Fall of potential tests are done with the ground system disconnected from the protected system. This may require either shutting down power or operating without ground protection for a period of time. When using a clamp-on tester, ground resistance can be measured without disconnecting the ground from the power system. This adds an extra measure of safety.*
- 2. The clamp-on tester saves time when performing the tests. The FOP method typically requires the stringing of leads (at times hundreds of feet). This creates the need for two operators as well as additional time required to set up the equipment.*
- 3. The clamp-on instrument is easy to operate. The operator simply clamps the tester on the ground rod or conductor leading to the ground rod and pushes the button. Within seconds the operator measurement is displayed.*

This type of measurement also offers the advantage of indicating the integrity of connections to the ground system as well as the overall ground resistance value. This provides an accurate and complete resistive representation of the path a lightning strike or ground fault must pass through to earth.

There are situations where a clamp-on tester is not appropriate for ground resistance measurements. In particular, it will not work if there are multiple connections from the same system to a common ground. However, for many applications, a clamp-on tester is appropriate, and easier to use.

Typical Testing Procedure

Remove any molding covering the ground conductor, and provide sufficient room for the jaws of the clamp-on ground tester. The clamp must be placed in such a way that the jaws are in an electrical path from the system neutral or a ground rod or rods as the circuit provides.

Clamp onto the ground conductor and measure the ground current. The maximum range is 30A. If the ground current exceeds 30A, ground resistance measurements are not possible. Do not proceed further with the measurement. Remove the clamp-on from the circuit, noting the location for maintenance, and continue to the next test location.

Having noted the ground current, select the ground resistance range "Ω" and measure the resistance directly. The reading you measure with the ground tester indicates not just the resistance of the rod, but of the connection to the system neutral and all bonding connections between the neutral and the rod.

Note: A high reading indicates one or more of the following:

- A) poor ground rod
- B) open ground conductor
- C) high resistance bond on the rod or splices on the connector; watch for buried split butts, clamps, and hammer-on connections.

Material for this article contributed by AEMC Instruments

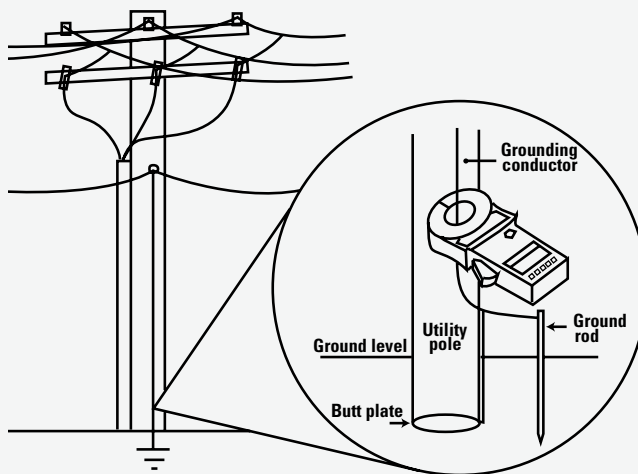

These clamp-on testers are ideal for:

- Pole-mounted transformers
- Service entrances and meters
- Pad-mounted transformers
- Transmission towers
- Anywhere in your plant or building where access is limited

Ground Testing

Engineer's Notebook

Large ground systems are important in protecting the electricity supply network. They ensure that fault current will enable protective devices to operate correctly. A system must have a low ground resistance to reduce the potentially dangerous, excessive voltages that develop during a fault.

In order to get a ground resistance that's low enough, large ground systems consist of many interconnected rods or of a large earth mat. Test techniques used on large systems to obtain valid readings are different from those used on a small single electrode (e.g., a residential ground), which is simple to test.

Fall of Potential Testing

For single-electrode grounds, current test spikes are fairly close (typically 30 to 60 ft) to the electrode under test. You can usually find a flat portion of the ground resistance curve that is close to the resistance of the electrode.

Testing several points or plotting a curve helps define the area around the electrode. You should always check the results by using a different direction or a longer distance to the test spikes. This helps eliminate errors caused by nearby buried conductors and other parts of the electrical system.

The Slope Method

The slope method lets you measure a large ground system without finding the flat portion of the characteristic curve. This can reduce the test distances, and the electrical center of the ground system is not required. Calculations are minimal, and you can easily check the result.

Take readings at 20%, 40%, and 60% to the current spike distance. The differences between these readings are used to fit to a model of the resistance characteristic. The coefficient of slope, is calculated from: $= (R_{60} - R_{40}) / (R_{40} - R_{20})$. Using a table of values vs. "actual distance" published in some user guides, you can retest this value to see if it fits the model.

Again, it is best to check the results by plotting the full characteristic and repeating the test using a different direction for the test spikes or a greater distance to the electrode.

Large Ground Systems

The physically large areas used by ground systems result in large "resistance areas" and great distances to the test spikes. This typically gives a ground resistance of less than 0.5Ω, allowing a good path for the large prospective fault current.

The distance to the electrode should be ten times the maximum dimension of the ground system. For one 6-ft electrode, this is not usually a problem, with a remote test spike at 60 ft. But it may be impractical for a substation with a 300-ft-square ground mat. A current electrode is required approximately 3,000 ft from the site. In cases like this, you can use a technique such as the slope method. This reduces the length of cable runs and is less likely to overlap with other local ground systems that might interfere with results.

Increase the Resolution

When measuring resistances of less than 1Ω in large ground systems, you need high-resolution readings for accurate measurements. A unit with 1 mΩ resolution—such as the MEGGER DET2/2—is appropriate. If you're using the fall of

Testing Large Ground Systems



potential or the slope method, small differences between low readings are significant. The extra digit of resolution makes these readings more accurate and compatible with standard reference tables.

Noise Interference

When induced noise is present, you need high noise-interference rejection to take readings, since a small signal has to be retrieved from a much larger total signal.

To remove the effect of noise, a frequency of 128 Hz is often used. This is close enough to line frequency to give results that can be used to make ground-fault current calculations. It avoids harmonics of the standard line frequencies to allow filtering of the test signal. A filter can remove the 50 or 60 Hz interference from the total signal.

Many ground testers only reject noise of a single frequency. This is usually inadequate, as electrical networks contain noise that consists of the frequency of the supply and its harmonics, high-frequency noise from switching, and induced signals from other sources. In some ground testers, this interference can cause significant measurement errors. These errors are not apparent to the user, since such instruments neither reject the noise nor trigger a high-noise annunciator.

With transient electrical noise—e.g., a train passing during testing of a railway system—testing can be delayed until the noise diminishes. However, in most cases background noise cannot be removed, so a suitable instrument is needed.

The MEGGER DET2/2's filtering system rejects more noise than other available earth testers. Adjustable test frequency and selectable levels of noise filtering also help remove stray noise. Its high current range increases the test-signal strength in relation to the noise. But, in extreme cases, you may still have to delay testing until the noise decreases.

CONCLUSIONS

The latest generation of digital instruments greatly simplifies ground-system testing. However, care is still needed in interpreting the results. Error indicators can alert you to misconnected leads or conditions that might cause an invalid reading, but taking one reading is not sufficient to measure the resistance of any ground system. Repeating the test using a different direction or distance can eliminate errors from hidden differences in the soil and confirm the initial results.

When selecting a ground tester, make sure that the resolution and accuracy are suitable for the application. Instrument errors can lead to unnecessary expense in the design or maintenance of ground systems or, worse still, unsafe installations.

NEW AEMC Digital Ground Resistance Testers

- Measures Soil Resistivity (4-Point) Method
- Measures Ground Resistance (2- and 3-Point) Fall-of-Potential Method
- Step Voltage Tests and Touch Potential Measurements
- Auto-Ranging: Automatically Selects the Optimum Range
- Designed to Reject High Levels of Noise and Interference
- Extremely Simple to Operate: Connect – Press – Read
- LEDs on Faceplate Informs Operator of High Input Noise, High Auxiliary Rod Resistance and Fault Connections
- Large Easy-to-Read Backlit Display
- Battery Powered (Model 4620)
- AC Powered with Rechargeable NiMH batteries (Model 4630)
- Rugged Dustproof and Rainproof Field Case
- Can also be used for Continuity Tests on Bonding
- Color-coded Terminals



B

Mfg#	4620	4630
Power Source	Eight C cell batteries; Alkaline recommended	120/230V 50/60Hz Rechargeable 9.6V, 3.5 Ah NiMH batteries

Specifications

Ranges (Auto-Ranging 0 to 2000Ω)	20Ω	200Ω	2000Ω
Measurement	0.00 to 19.99Ω	20.0 to 199.9Ω	200 to 1999Ω
Resolution	10mΩ	100mΩ	1Ω
Open Voltage	<42V peak		
Resistance Measurement Frequency	128Hz square wave		
Current	10mA	1mA	0.1mA
Accuracy	±2% of Reading ± 1ct		±3% of Reading ± 3cts
Auxiliary Electrode Influence			
Max Res. in Current Circuit	200Ω	30kΩ	50kΩ
Max Res. in Voltage Circuit	2000Ω	50kΩ	50kΩ
Response Time	Approximately 6 seconds for a stabilized measurement		
Withstanding Voltage	250Vac with spikes of 3000Vac or 1000Vdc		
Battery Life	1800 15-second measurements; "LO BAT" indication on LCD		
Fuse Protection	0.1A, 250V, 0.25 x 1.25"; 30kA Interrupt Capacity		



Ground Resistance Tester Model 4630 Kits include meter, two 300 ft color-coded leads on spools, two 100 ft color-coded leads, four 16" auxiliary ground electrodes, one 16 ft lead with Mueller® clip, carrying bag, one 100 ft tape measure, one AC power cord, ground workbook and user manual

Electrical Test Instruments

Ordering Information

Order #	Mfg #	Description	Price
MP2130.43	4620	Ground Resistance Tester Model 4620 (4-Point, Digital, Battery Powered)	
MP2130.44	4630	Ground Resistance Tester Model 4630 (4-Point, Digital, Rechargeable Battery)	
MP2130.45	4620	Ground Resistance Tester Model 4620 Kit	
MP2130.46	4630	Ground Resistance Tester Model 4630 Kit	

Accessories

Order #	Mfg #	Description	Price
MP2130.60	2130.60	Tape Measure (100 ft)	
MP2130.61	2130.61	Ground Test Kit – 3-Point (supplemental 4-Point) includes carrying bag, two 100 ft color-coded leads, one 16 ft lead and two 16" auxiliary ground electrodes	
MP2130.62	2130.62	Test Kit – 3-Point includes carrying bag, two 150 ft color-coded leads on spools, two 16" auxiliary ground electrodes, one 16 ft lead with Mueller® clip and one 100 ft tape measure	
MP2130.63	2130.63	Test Kit – 4-Point includes carrying bag, two 300 ft color-coded leads on spools, two 100 ft color-coded leads, four 16" auxiliary ground electrodes, one 16 ft lead with Mueller® clip and one 100 ft tape measure	

NEW AEMC Fall-of-Potential Ground Resistance Tester

B

- Large Analog Display (Model 3620)
- Large LCD Digital Display (Models 3640 and 4610)
- Designed to Reject High Levels of Noise and Interference
- Auto-Ranging: Automatically Selects the Optimum Range (Models 3640 and 4610)
- Battery Powered
- Performs Fall-of-Potential Method
- Measure Ground Resistance (2- and 3-Point)
- Model 4610 also Measures Soil Resistivity (4-Point)
- Extremely Simple to Operate: Connect-Press-Read
- Indicator Error Lights
- Rugged Dustproof and Rainproof Case
- Color-Coded Terminals and Lead Identification



Model 4610 kit includes meter, one 16 ft color-coded lead, two 100 ft color-coded leads, two 300 ft leads on reels, four auxiliary ground electrodes, soft carrying case, batteries and user manual.

Model 3640 kit includes meter, one 16 ft lead, two 150 ft leads on spools with wind-up handles, two auxiliary ground electrodes, soft carrying case, batteries and user manual.

Model 3620 kit includes meter, one 16 ft lead, two 150 ft leads on spools with wind-up handles, two auxiliary ground electrodes, soft carrying case, batteries and user manual.

4610 Kit ▲

Electrical Test Instruments

Specifications

Mfg #	3620	3640	4610	
Types of Measurements	2- & 3-Point	2- & 3-Point	2-, 3-, & 4-Point	
Display	Analog	Digital	Digital	
Soil Resistivity Tests	No	No	Yes	
Measurement Ranges	0.5 to 1000Ω	20Ω: 0.00 to 19.99Ω	200Ω: 20.0 to 199Ω	2000Ω: 200 to 1999Ω
Resolution	—	10mΩ	100mΩ	1Ω
Test Current	10mA	10mA	1mA	0.1mA
Open Voltage	≤24V peak	≤42V peak		
Operating Frequency	128Hz square wave			
Accuracy	±5% of Reading + 0.1% scale length	±2% of Reading ± 1ct	±3% of Reading ± 3cts	
Interference	All models reject high levels of in interference voltage (DC, 50 to 60 Hz, harmonics)			
Power Source	Eight 1.5V AA batteries			
Battery Life	Approx. 1680 fifteen-second measurements	Approx. 1800 fifteen-second measurements		
Low Battery Indication	Yes			
Fuse Protection	High breaking capacity, 0.1A, 250V			



3620 ▲

All individual units include soft carrying case



3640 ▲



4610 ▲

Ordering Information

Order #	Mfg #	Description	Price
MP23835E	2114.91	Ground Resistance Tester Model 3620 Kit	
MP2386E	2114.93	Ground Resistance Tester Model 3640 Kit	
MP5072GRT	2114.95	Ground Resistance Tester Model 4610 Kit	
MP2114.90	2114.90	Ground Resistance Tester Model 3620 (3-Point, Analog)	
MP2114.92	2114.92	Ground Resistance Tester Model 3640 (3-Point, Digital)	
MP5073GRT	2114.94	Ground Resistance Tester Model 4610 (4-Point, Digital)	

Megger Three-Terminal Analog Ground Resistance Tester

Quick, easy ground rod testing

- Quick, Routine Single-Ground Rod Tests
- Simple, Single-Switch Operation
- Measures Ground Resistance Down to 0.5Ω

The 8175E is an economical choice for electrical contractors, plant electricians, and telephone/CATV technicians making routine ground resistance tests on single-ground rods or simple grounding systems. Use it to test utility pole grounds, residential wiring systems, machinery safety grounds, distribution transformers, and more. The tester's three terminals provide full of potential earth resistance measurements. Adjust the three-position switch to read the measurement, check the probe resistance, and turn it off. Powered by four C alkaline batteries, it has a measurement range of 0.5Ω to 100Ω, displayed in ohms on the analog scale. The optional, but recommended, accessory kit contains everything you need, including two 12-inch grounding rods and three test leads (10, 31, and 50' in length), plus a plug-in calibration standard with 5Ω and 100Ω check.

Each Unit Includes: Four alkaline C cell batteries and instruction manual.

Specifications

Resistance Range:	0.5–500Ω
Test Vicinity:	60 Hz
Frequency:	135 Hz
Accuracy:	±2% of Full Scale deflection to 100Ω
Output Voltage:	5V maximum
Size/Weight:	7.5 x 6.5 x 4.75" HWD/2.8 lbs

250260 ▶



B

Ordering Information

Order #	Mfg #	Description	Price
MP8175E	250260	Ground Resistance Tester	
MP8176E	217719	Carrying Case	
MP8177E	250560	Test Kit (Optional)	

Transcat Accredited Calibration with Data	CALL
Transcat Accredited Calibration without Data	CALL

AEMC Ground Resistance Tester

- Measures Ground Resistance (2- and 3-Point) and Soil Resistivity (4-Point)
- Step Voltage Tests and Touch Potential Measurements
- Measures Very Low Resistance on Large Grounding Systems and Grids
- High Test Current Also Enables Geological Surveys
- Display Includes Indicators for Excess Stray Current, High Stray Voltage, High Rod Resistance, and Faulty Connection
- Battery Powered (Rechargeable 110V/220V)
- Rugged Dustproof and Rainproof Case

Each Unit Includes: Rechargeable battery or external 12 VAC, carrying case, and user's manual.

Each 3242E Includes: Two 500' lead wires, one 30' lead wire, two ground rods, and carrying bag.

Each 2130.61 Includes: Two 100' color codeds, one 16' lead lead wires and two 16" ground electrodes.

Specifications

Range:	2Ω	20Ω	200Ω	2000Ω	20 kΩ
Resolution:	1 mΩ	10 mΩ	0.1Ω	1Ω	10Ω
Test Current Ranges:	2 mA, 10 mA, 50 mA				
Accuracy:	±2% of Rdg ±1 ct from 10–100% of range				
Operating Freq.:	128 Hz square wave				
Maximum Auxiliary:	50 kΩ on 20Ω, 200Ω, 2000Ω, 20 kΩ ranges				
Electrode Resistance:	15 kΩ at 2 mA/3000Ω at 10 mA/600Ω at 50 mA				
Display:	7-segment LCD, 0.71", 3 1/2-digit, 2000 counts				

450.100 ▶



Ordering Information

Order #	Mfg #	Description	Price
MP3241E	450.100	Model 4500 Ground Resistance Test Kit	
MP3242E	100.525	Test Kit, 500 ft leads	
MP2130.61	2130.61	Test Kit, 100 ft leads	

Transcat Accredited Calibration with Data	CALL
Transcat Accredited Calibration without Data	CALL

Electrical Test Instruments

Megger Ground Resistance Tester

Measure ground resistance at the touch of a button

- Three-Terminal Measurement
- Terminals Accept Spade or Hook Connections, 4 mm Plugs, or Bare Wire
- 40V Peak-To-Peak Interference Tolerance
- Resistance Range From 0.1Ω to 1.99 kΩ (Autoranging)
- Microprocessor Controlled for Improved Error Detection
- Pushbutton, Fully Automatic Operation
- Weatherproof Case (Protection to IP54) for Outdoor Use
- Ideal for Single-Ground Systems
- Meets National Electrical Code regulations, including IEC364, VDE 0413, and BS7671

Pushbutton Operation and Automatic Error Indication

The unit chooses the best of two autoranging ground resistance ranges, covering measurements from 0.1Ω to 1.99 kΩ, then displays the reading accurately and quickly on a large, clear 3.5-digit LCD (which also shows battery life). An industry-best 40 volt peak-to-peak interference tolerance increases the variety of environments you can operate this unit in successfully.

Ordering Information

Order #	Mfg #	Description	Price
MP23046E	DET62D	Three-Terminal Digital Ground Tester	
MP8187E	250579	Standard Accessory Kit	
MP4261E	250581	Deluxe Accessory Kit	

Transcat Accredited Calibration with Data	CALL
Transcat Accredited Calibration without Data	CALL

DET62D ▶



Each Unit Includes: Terminal shorting bar, six AA batteries, and operating instructions.

Standard Kit Includes: 3 color-coded test leads (25, 50, 100 ft), pair of 20" ground rods, and canvas case for leads and rods only.

Deluxe Kit Includes: 3 color-coded test leads (25, 50, 100 ft), pair of 20" ground rods, padded case for instrument, leads, and rods.
NOTE: Rod kits are required and must be ordered separately.

Specifications

Resistance Range:	0.1Ω to 1.999 kΩ
Resolution:	0.1Ω
Test Voltage:	Maximum 50V
Test Frequency:	128 Hz ±0.5 Hz/Maximum 50V
Accuracy:	±2% of reading ±3 digits
Maximum Current Loop Resistance:	200Ω Range: 40 kΩ ±5 kΩ 2 kΩ Range: 400 kΩ ±50 kΩ
Size/Weight:	9.4 x 6 x 2.75" HWD/1.5 lbs

Megger Ground Resistance Testers

Fall of potential, slope, and soil resistivity testing—
one unit does it all

- Four Ranges from 0.01Ω to 19.99 kΩ (Autoranging)
- 40V Peak-to-Peak Interference Tolerance
- Improved Error Detection
- Fully Automatic Operation
- Three- or Four-Terminal Measurement
- NEC Codes IEC364, VDE 0413, and BS7671

They are ideal for fall of potential and slope method testing, as well as soil resistivity measurements to map for ground-bed site selection. The units continually check for conditions, such as high spike resistance or excessive noise, that might invalidate a test. When this occurs, the LED display alerts you that a valid reading cannot be taken.

Each Unit Includes: Two terminal shorting bars, power/charging cord, and operating instructions.

Each 8187E Standard kit Includes: 3 color-coded test leads; (25, 50, 100 ft), pair of 20" ground rods, canvas case for leads and rods only.

Each 4261E Deluxe kit Includes: 3 color-coded test leads; (25, 50, 100 ft), pair of 20" ground rods, padded case for leads, rods, and instrument.

Each 22254E-TL Soil resistivity kit Includes: Set of 4 test leads (50 ft), two pairs of 20" ground rods, carrying case for leads and rods only.

DET5/4R ▶



Specifications

	22255E-1	22255E-2
Power Supply:	Rechargeable battery	Six 1.5V AA dry cells
Resistance Range:	0.01Ω–19.99 kΩ	
Resolution:	0.01Ω	
Frequency:	128 Hz ±0.5 Hz	
Accuracy:	± 2% or reading ±3 digits	
Size/Weight:	9.4 x 6 x 2.75" HWD/2.8 lbs	

Ordering Information

Order #	Mfg #	Description	Price
MP22255E-1	DET5/4R	Digital Ground Tester, Rechargeable Batteries	
MP22255E-2	DET5/4D	Digital Ground Tester, Standard Batteries	
MP8187E	250579	Standard Accessory Kit	
MP4261E	250581	Deluxe Accessory Kit	
MP22254E-TL	250586	Soil Resistivity Kit	

Transcat Accredited Calibration with Data	CALL
Transcat Accredited Calibration without Data	CALL

Megger High-Sensitivity Ground Resistance Tester

The high sensitivity choice for the broadest range of applications

- Wide Resistance Range from 0.01Ω to 19.99 kΩ (Autoranging)
- ±0.5% of Reading Accuracy ±2 Digits
- Continuously Adjustable Test Frequency from 105–160 Hz
- 40V Peak-to-Peak Interference Tolerance
- Microprocessor-Controlled for Improved Error Detection

The 4260E four-terminal digital ground tester gives you the broadest range of ground testing applications of any instrument currently available. Its advanced features make it the right choice for testing large, complex ground systems and in difficult testing environments, like substations and switchyards. Use it for fall of potential and slope method testing, as well as soil resistivity measurements to map ground-bed site selection. It's ideal for generator, substation and switchyard grounds; computer and communications systems grounds; EMI/RFI systems; antennas, central office, and pedestal grounds; or CATV systems.

Designed For Highest Sensitivity and Precision

In addition to its 40V peak-to-peak interference tolerance and 0.001Ω resolution, you'll welcome its interference filter (on/off) and test current control (high/low). Test current frequency is adjustable in half-Hertz increments over the full range from 105–160 Hz. An annunciator alerts you whenever soil transients are affecting measurements. Just dial a test frequency away from that harmonic, and readings stabilize. Ideal for utility substations or heavy industrial environments, it alerts you to excessive input noise and high current probe resistance. It chooses the range for best resolution, and its simple menus make for error-free operation.

Each Unit Includes: Ten test record cards (4584E); rechargeable internal NiCd battery pack, power cord, and internal charger; manufacturer's certificate of conformance, and instructions.

Each 8187E Kit Includes: Three color-coded test leads (25, 50, 100 ft), pair of 20" ground rods, and canvas case for leads and rods only.

Each 4261E Deluxe Kit Includes: Three color-coded test leads (25, 50, 100 ft), pair of 20" ground rods, padded case for leads, rods, and instrument.

Each 22254E-TL Soil Resistivity Kit Includes: Set of four test leads (50 ft), two pairs of 20" ground rods, carrying case for leads and rods only.



▲ 250202

Specifications

Resistance Range:	0.01Ω–19.99 kΩ
Resolution:	0.001Ω
Frequency:	Adjustable 105–160 Hz
Accuracy:	±0.5% of reading ±2 digits
Size/Weight:	13.5 x 9.6 x 6.25" HWD/11 lbs

Ordering Information

Order #	Mfg #	Description	Price
MP4260E	250202	Digital High-Sensitivity Ground Tester	
MP8187E	250579	Standard Accessory Kit	
MP4261E	250581	Deluxe Accessory Kit	
MP22254E-TL	250586	Soil Resistivity Kit	

Transcat Accredited Calibration with Data	CALL
Transcat Accredited Calibration without Data	CALL

B

Electrical Test Instruments